



PHT Pressure Transmitter for Sanitary Applications

The high-quality SICK PHT pressure transmitters are perfectly suited for sanitary applications in the food and beverage, pharmaceutical and cosmetics industry.

Regarding the process the pressure transmitters are characterized by their design free from cavities using flush-mounted membranes and a large range of available sanitary process connections. Amongst others, the devices are available with tri-clamp, DIN and ISO clamp connections, female union nut connections according to DIN 11851 and 11862-1 as well as VARIVENT connections. Wetted parts are made from high-grade 1.4435 stainless steel with surface roughness $Ra < 0.4\mu\text{m}$.

To accommodate the frequent elevated process temperatures as well as the requirements of CIP and SIP processes the PHT pressure transmitters are rated for process temperatures up to 150°C . According to the requirements in the food and beverage industry the pressure transmitting fluid is FDA compliant.

The pressure transmitters PHT are distinguished by their highly precise measurement technology based on piezo-resistive sensors. Between $0\text{...}0.25\text{ bar}$ and $0\text{...}25\text{ bar}$ a wide range of usefully graded gauge measurement ranges is available. In addition, there are absolute measurement ranges from $0\text{...}0.25\text{ bar}$ up to $0\text{...}16\text{ bar}$ and compound ranges between $-1\text{...}0\text{ bar}$ and $-1\text{...}+15\text{ bar}$ available. The PHT pressure transmitters provide an output signal that is proportional to the applied pressure. They are available with output signals $4\text{...}20\text{ mA}$, $0\text{...}5\text{ V}$, or $0\text{...}10\text{ V}$.

For specifically harsh environmental conditions the PHT pressure transmitters are available with a stainless steel field housing. The variant with field housing and current output $4\text{...}20\text{ mA}$ features test terminals that allow metering of the signal current without having to disconnect the device.

Benefits

- Safe hygienic operation through EHEDG certification
- High reliability and availability through robust design and use of high-grade materials
- High system availability due to CIP/SIP-ability
- Good cleanability of the transmitter housing
- Optimized solutions through versatile configurability



Technical Data

Measuring ranges	Unit	Pressure ranges	Overpressure safety	Burst pressure	Pressure ranges	Overpressure safety	Burst pressure
	bar	0 ... 0.25	2	2.4	0 ... 4	17	20.5
		0 ... 0.4	2	2.4	0 ... 6	35	42.0
		0 ... 0.6	4	4.8	0 ... 10	35	42.0
		0 ... 1	5	6.0	0 ... 16	80	96.0
		0 ... 1.6	10	12.0	0 ... 25	80	96.0
		0 ... 2.5	10	12.0			
	bar abs	0 ... 0.25	2	2.4	0 ... 4	17	20.5
		0 ... 0.4	2	2.4	0 ... 6	35	42.0
		0 ... 1	5	6.0	0 ... 10	35	42.0
		0 ... 1.6	10	12.0	0 ... 16	80	96.0
		0 ... 2.5	10	12.0			
	bar	-1 ... 0	5	6.0	-1 ... +5	35	42.0
		-1 ... +0.6	10	12.0	-1 ... +9	35	42.0
		-1 ... +3	17	20.5	-1 ... +15	80	96.0
	Unit	Pressure ranges	Overpressure safety	Burst pressure	Pressure ranges	Overpressure safety	Burst pressure
	MPa	-0.1 ... 0	0.5	0.6	0 ... 0.4	1.7	2.0
		-0.1 ... +0.3	1.7	2.0	0 ... 0.6	3.5	4.2
		-0.1 ... +1.5	8.0	9.6	0 ... 1	3.5	4.2
		0 ... 0.04	0.2	0.24	0 ... 1.6	8	9.6
		0 ... 0.1	0.5	0.6	0 ... 2.5	8	9.6
		0 ... 0.25	1.0	1.2			
	Unit	Pressure ranges	Overpressure safety	Burst pressure	Pressure ranges	Overpressure safety	Burst pressure
	psi	0 ... 5	29	34.8	0 ... 100	500	600
		0 ... 10	29	34.8	0 ... 160	500	600
		0 ... 30	145	170	0 ... 200	1160	1390
		0 ... 60	246	297	0 ... 300	1160	1390
	psi abs	0 ... 15	72.5	87	0 ... 100	500	600
		0 ... 25	145	170	0 ... 250	1160	1390
		0 ... 50	240	290			
	psi	-30 InHg...0	72.5	87			
	Unit	Pressure ranges	Overpressure safety	Burst pressure	Pressure ranges	Overpressure safety	Burst pressure
	kg/cm ²	-1...0	5	6.0	0 ... 10	35	42.0
		0 ... 2.5	10	12.0	0 ... 16	80	96.0
		0 ... 4	17	20.5	0 ... 25	80	96.0
		0 ... 6	35	42.0			

Technical Data

Type	PHT
Process connections	Tri-Clamp 1 ½ ", 2 "
	Clamp DIN 32 676 DN 32, 40, 50
	Clamp ISO 2852 DN 33,7, 38, 40, 51
	Female union nut DIN 11 851 DN 25, 40, 50
	Female union nut SMS DN 1 ½ ", 2 "
	VARIVENT® form F, N
	Female union nut DIN 11 864-1 DN 40 DN 50, flange DIN 11 864-2 DN 40 DN 50, clamp DIN 11 864-3 DN 40 DN 50
	NEUMO BioControl® size 50, 65
	NEUMO BioConnect® form V - DN 40, 50
	NEUMO BioConnect® thread with union nut DN 40, 50
	Flange connection DRD
	Further connections on request
Materials	
■ Wetted parts	Stainless steel 1.4435
■ Housing	Stainless steel 1.4571
■ Pressure transmitting fluid	Synthetic oil, FDA approved
Power supply L ⁺	10 ... 30 V 14 ... 30 V with signal output 0 ... 10 V 11 ... 30 V with signal output 4 ... 20 mA and field housing
Signal output and maximum load R _A	4 ... 20 mA, 2-wire, R _A ≤ (L ⁺ - 10 V) / 0.02 A [Ohm] The variant with field housing and current output 4...20 mA features test terminals that allow metering of the signal current without having to disconnect the device.
	0 ... 10 V, 3-wire, R _A > 10 kOhm (optional)
	0 ... 5 V, 3-wire, R _A > 5 kOhm (optional)
Adjustability zero/span	± 5 % using potentiometer inside the instrument ¹⁾
Response time (10 ... 90 %)	≤ 10 ms
Dielectric strength	500 V DC ²⁾
Accuracy ³⁾	≤ ± 0.5 % of span, optional 0.25 % of span (adjusted in vertical mounting position with lower pressure connection)
Non-linearity	≤ ± 0.2 % of span, (BFSL) per IEC 61298-2
Non-repeatability	≤ ± 0.1 % of span
1-year stability	≤ ± 0.2 % of span, (at reference conditions)
Permissible temperature ranges	
■ Medium	-20 ... +150 °C
■ Ambient	-20 ... +80 °C
■ Storage	-40 ... +100 °C
Compensated temperature range	0 ... +80 °C
Temperature coefficients within compensated temperature range:	
■ Mean TC of zero	≤ 0.2 % of span/ 10 K, with pressure ranges 0 ... 0.6 bar to 0 ... 25 bar
	≤ 0.25 % of span/ 10 K, with pressure range 0 ... 0.4 bar
	≤ 0.4 % of span/ 10 K, with pressure range 0 ... 0.25 bar
■ Mean TC of range	≤ 0.2 % of span/ 10 K

¹⁾ Not with cable connections order codes 4 and 5

²⁾ NEC Class O2 power supply (low voltage and low current max. 100 VA even under fault conditions)

³⁾ Including non-linearity, hysteresis, zero point and full scale error (corresponds to error of measurement per IEC 61298-2)

Technical Data

Type	PHT
CE-conformity	
■ EMC directive	2004/108/EEC, EN 61 326-2-3
Protection class	III
Shock resistance	500g per IEC 60068-2-27 (mechanical shock)
Vibration resistance	15g per IEC 60068-2-6 (vibration under resonance)
Electrical connection	4-pin L-connector per EN 175301-803, form A Stainless steel field housing with internal spring clip terminal, cross section max. 2.5 mm ² Circular connector M12 x 1, 4-pin Flying leads with 1,5 m or 3 m vented cable (zero/span not adjustable), other lengths upon request
Wiring protection	
■ Wiring protection	36 V DC
■ Overvoltage protection	Q _A towards M
■ Short-circuit proofness	L ⁺ towards M
Enclosure rating	IP 67 for configuration with field housing IP 68 for configuration with integrated cable output IP 67 for configuration with electrical connector M12x1 IP 65 for configuration with L-connector Per IEC 60 529 / EN 60 529. The ingress protection classes specified only apply when the pressure transmitter is connected with female connectors that provide the corresponding ingress protection.)
Weight	Approx. 0.5 kg (ca. 0.6 kg with option accuracy 0.25 % of span)

Electrical connections

DIN 175301-803 A
L-connector
Conductor cross section
up to max. 1.5 mm²,
conductor outer diameter
6-8 mm, IP 65
Order code: L

Stainless steel field housing
IP 67
Ground terminals, brass
nickel-plated
Order code: F

M12 x 1
Circular connector
4-pin
IP 67
Order code: M

Flying leads
zero/span not adjustable,
for conductor cross section
up to max. 0.5 mm², AWG 20
with end splices, conductor
outer diameter 6.8 mm, IP 68
Order code: 4: Length 1.5 m
5: Length 3 m

Connectors are not
included in delivery

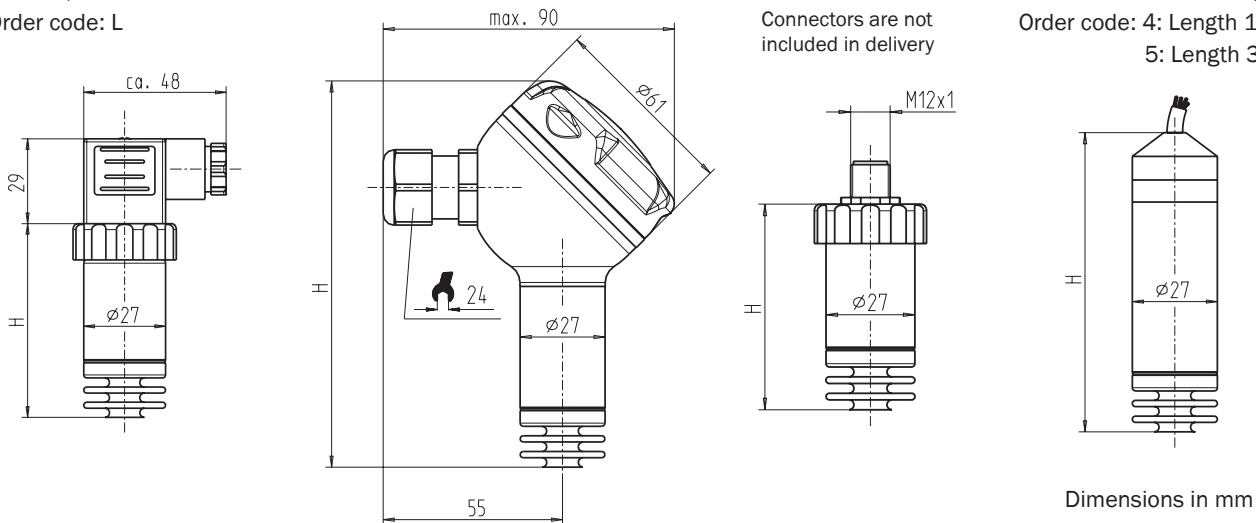

Dimensions in mm

Design	Dimension H in mm with accuracy 0.5 %	Dimension H in mm with accuracy 0.25 %
L-connector	64	84
Field housing	123	138.5
M12 x 1	64	84
Flying leads	79.5	95

Process connections

Clamp

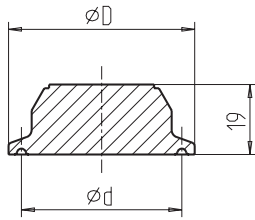

Design		Dimensions in mm	
		ØD	Ød
Tri-Clamp	1 1/2"	50	43.5
	2"	64	56.6
DIN 32 676	DN 32	50	43.5
	DN 40	50	43.5
	DN 50	64	56.6
ISO 2852	DN 33.7	50	43.5
	DN 38	50	43.5
	DN 40	64	56.6
	DN 51	64	56.6

Female union nut

DIN 11 851

with union nut,
for pipes per
DIN 11 850

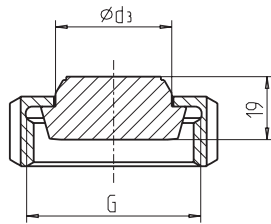

Design		Dimensions in mm	
		G	Ød ₃
DIN 11 851	DN 25	Rd 52 x 1/6	44
	DN 40	Rd 65 x 1/6	48
	DN 50	Rd 78 x 1/6	61

Female union nut

SMS

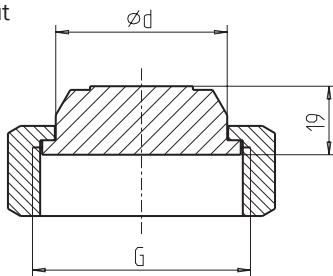

Design		Dimensions in mm	
		G	Ød ₃
SMS	1 1/2"	Rd 60 x 1/6	47.5
	2"	Rd 70 x 1/6	60

VARIVENT®

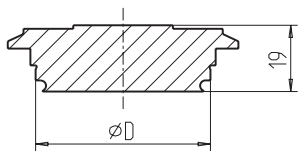

Design		Dimensions in mm	
		ØD	
VARIVENT®	Form F	50	
	Form N	68	

Female union nut
DIN 11 864-1

with union nut, Form A for pipes per DIN 11 850 and DIN 11 866, row A

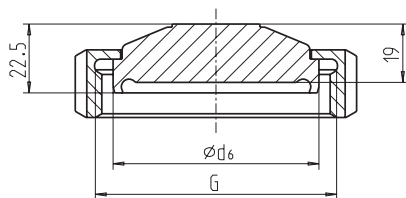

Design		Dimensions in mm	
		G	Ød ₆
DIN 11 864-1	DN 40	Rd 65 x 1/6	54.9
	DN 50	Rd 78 x 1/6	66.9

Flange connection
DIN 11 864-2

with aseptic flange with notch, for pipes per
DIN 11 850 and DIN 11 866, row A

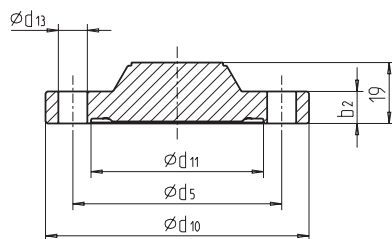

Design		Dimensions in mm				
		Ød ₅	Ød ₁₀	Ød ₁₁	Ød ₁₃	Øb ₂
DIN 11 864-2	DN 40	65	82	53.7	4 x 9	10
	DN 50	77	94	65.7	4 x 9	10

Process connections

Clamp
DIN 11 864-3 with aseptic clamp connection with notch, for pipes per DIN 11 850 and DIN 11 866, row A

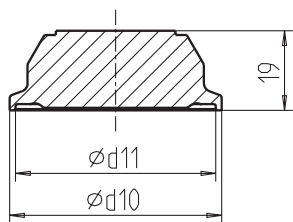

NEUMO
BioControl®

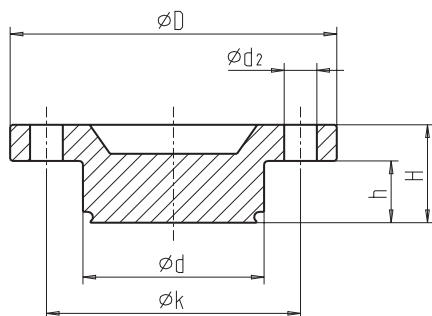

NEUMO
BioConnect® Flange form V

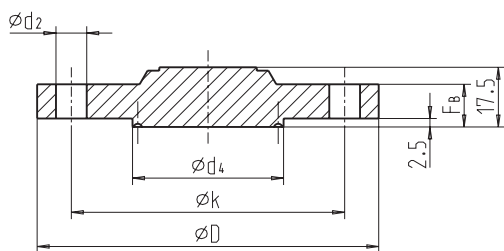

NEUMO
BioConnect® Thread with union nut (Form V)

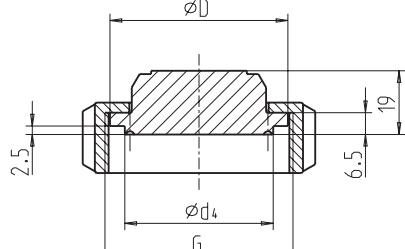

Flange connection
DRD

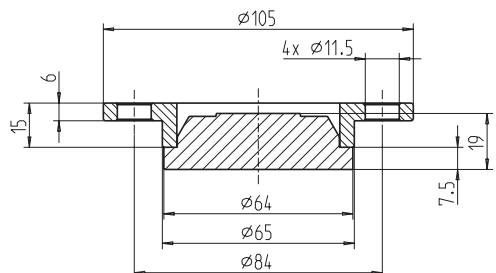



Design	Dimensions in mm		
		$\varnothing d_{10}$	$\varnothing d_{11}$
DIN 11 864-3	DN 40	64	53.7
	DN 50	77.5	65.7

Design	Dimensions in mm						
		$\varnothing d$	$\varnothing d_2$	$\varnothing D$	$\varnothing k$	h	H
BioControl®	Gr. 50	50	4x9	90	70	17	27
	Gr. 65	68	4x11	120	95	17	27

Design	Dimensions in mm					
		$\varnothing d_2$	$\varnothing d_4$	$\varnothing D$	$\varnothing k$	F_B
BioConnect®	DN 40	4x9	44.2	100	80	10
	DN 50	4x9	56.2	110	90	12

Design	Dimensions in mm			
		G	$\varnothing d_4$	$\varnothing D$
BioConnect®	DN 40	M56 x 2	44.2	53
	DN 50	M68 x 2	56.2	65

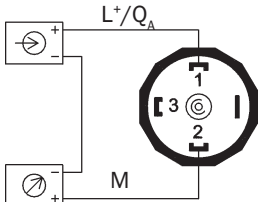
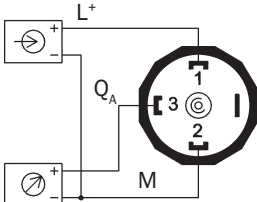
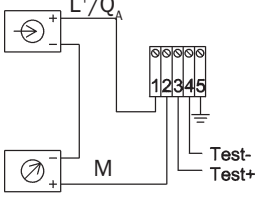
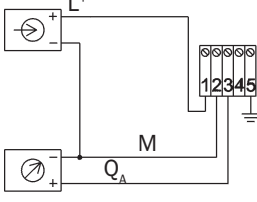
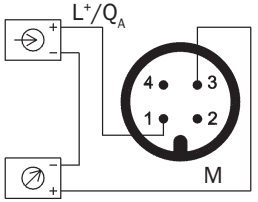
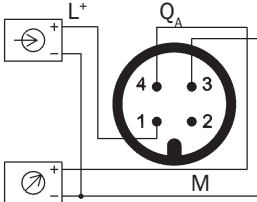
Wiring details

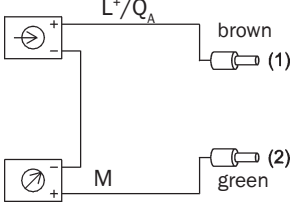
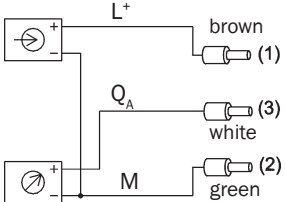
Version	2-wire	3-wire
L-Connector DIN 175301-803 A		
Stainless steel field housing		
Circular connector M12 x 1, 4-pin		
Flying leads Legend:  Power supply  Load (e.g. display)		

Type Code

Pressure type

R	Gauge
A	Absolute
C	Compound

Pressure unit

B	bar
M	MPa
P	psi
K	kg/cm ²

Standard measurement ranges see the following pages

Accuracy

S	Accuracy +/- 0.5% of Span (BFSL)
E	Accuracy +/- 0.25% of Span (BFSL)

Process connector

T1	Tri-Clamp DN 1 ½" ¹⁾
T2	Tri-Clamp DN 2" ¹⁾
52	Female union nut DIN 11851 DN 25 ¹⁾
54	Female union nut DIN 11851 DN 40 ¹⁾
55	Female union nut DIN 11851 DN 50 ¹⁾
64	Female union nut DIN 11864-1 DN 40
65	Female union nut DIN 11864-1 DN 50 ¹⁾
74	Clamp DIN 11864-3, DN 40
75	Clamp DIN 11864-3, DN 50
84	Flange DIN 11684-2, DN 40
85	Flange DIN 11684-2, DN 50
C2	Clamp ISO 2852 DN 33.7 ¹⁾
C3	Clamp ISO 2852 DN 38 ¹⁾
C4	Clamp ISO 2852 DN 40 ¹⁾
C5	Clamp ISO 2852 DN 51 ¹⁾
D3	Clamp DIN 32676 DN 32 ¹⁾
D4	Clamp DIN 32676 DN 40 ¹⁾
D5	Clamp DIN 32676 DN 50 ¹⁾
N4	NEUMO BioConnect DN 40 Form V
N5	NEUMO BioConnect DN 50 Form V
N6	NEUMO BioConnec thread with union nut DN 40
N7	NEUMO BioConnec thread with union nut DN 50
N8	NEUMO BioControl Size 50
N9	NEUMO BioControl Size 65
VF	Varivent Connector Type F ¹⁾
VN	Varivent Connector Type N ¹⁾
DR	DRD Connector with clamping elements

PHT -						0	S					0	Z
-------	--	--	--	--	--	---	---	--	--	--	--	---	---

¹⁾ EPDM sealing optional available

Type Code

Process connector

- S1 Grooved union nut SMS standard DN 1 ½"
- S2 Grooved union nut SMS standard DN 2"

Sealing

- E EPDM ²⁾
- 0 Without sealing

Signal output

- A 4 ... 20 mA, 2-wire
- V 0 ... 10 V, 3-wire
- U 0 ... 5 V, 3-wire

Electrical connector and housing

- M M12 x 1, 4-pin, IP 67
- L L-connector DIN EN 175301-803 A, IP65
- 4 flying leads, 1.5 m, IP 68 (zero and span not adjustable)
- 5 flying leads, 3 m, IP 68 (zero and span not adjustable)
- F Field housing IP 67

Supply voltage

- S 10 ... 30 V DC
- Z 14...30 V DC with signal output 0 ... 10 V
- T 11 ... 30 V DC with signal output 4 ... 20 mA and field housing

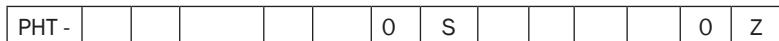

²⁾ Availability of sealing refer to footnote 1) on previous page.

Type Code

Measurement ranges	bar / Gauge Pressure		bar / Absolute Pressure		bar / Compound Pressure	
X25	0 ... 0,25 bar		X25	0 ... 0.25 bar abs	1X0	-1 ... 0 bar
X40	0 ... 0,4 bar		X40	0 ... 0.4 bar abs	1X6	-1 ... +0.6 bar
X60	0 ... 0,6 bar		1X0	0 ... 1 bar abs	4X0	-1 ... +3 bar
1X0	0 ... 1 bar		1X6	0 ... 1.6 bar abs	6X0	-1 ... +5 bar
1X6	0 ... 1,6 bar		2X5	0 ... 2.5 bar abs	010	-1 ... +9 bar
2X5	0 ... 2,5 bar		4X0	0 ... 4 bar abs	016	-1 ... +15 bar
4X0	0 ... 4 bar		6X0	0 ... 6 bar abs		
6X0	0 ... 6 bar		010	0 ... 10 bar abs		
010	0 ... 10 bar		016	0 ... 16 bar abs		
016	0 ... 16 bar					
025	0 ... 25 bar					

	MPa / Gauge Pressure		MPa / Compound Pressure	
40M	0 ... 0.04 MPa		X10	-0,1 ... 0 MPa
X10	0 ... 0.1 MPa		X40	-0,1 ... +0,3 MPa
X25	0 ... 0.25 MPa		1X6	-0,1 ... +1,5 MPa
X40	0 ... 0.4 MPa			
X60	0 ... 0.6 MPa			
1X0	0 ... 1 MPa			
1X6	0 ... 1.6 MPa			
2X5	0 ... 2.5 MPa			

	psi / Gauge Pressure		psi / Absolute Pressure		psi / Compound Pressure	
5X0	0 ... 5 psi		015	0 ... 15 psi abs	015	-30 InHg ...0 psi
010	0 ... 10 psi		025	0 ... 25 psi abs		
030	0 ... 30 psi		050	0 ... 50 psi abs		
060	0 ... 60 psi		100	0 ... 100 psi abs		
100	0 ... 100 psi		250	0 ... 250 psi abs		
160	0 ... 160 psi					
200	0 ... 200 psi					
300	0 ... 300 psi					

	kg/cm ² / Gauge Pressure		kg/cm ² / Compound Pressure	
2X5	0 ... 2,5 kg/cm ²		1X0	-1...0 kg/cm ²
4X0	0 ... 4 kg/cm ²			
6X0	0 ... 6 kg/cm ²			
010	0 ... 10 kg/cm ²			
016	0 ... 16 kg/cm ²			
025	0 ... 25 kg/cm ²			

Notes

Australia

Phone +61 3 9497 4100
1800 33 48 02 – tollfree
E-Mail sales@sick.com.au

Belgium/Luxembourg

Phone +32 (0)2 466 55 66
E-Mail info@sick.be

Brasil

Phone +55 11 3215-4900
E-Mail sac@sick.com.br

Ceská Republika

Phone +420 2 57 91 18 50
E-Mail sick@sick.cz

China

Phone +852-2763 6966
E-Mail ghk@sick.com.hk

Danmark

Phone +45 45 82 64 00
E-Mail sick@sick.dk

Deutschland

Phone +49 211 5301-301
E-Mail info@sick.de

España

Phone +34 93 480 31 00
E-Mail info@sick.es

France

Phone +33 1 64 62 35 00
E-Mail info@sick.fr

Great Britain

Phone +44 (0)1727 831121
E-Mail info@sick.co.uk

India

Phone +91-22-4033 8333
E-Mail info@sick-india.com

Israel

Phone +972-4-999-0590
E-Mail info@sick-sensors.com

Italia

Phone +39 02 27 43 41
E-Mail info@sick.it

Japan

Phone +81 (0)3 3358 1341
E-Mail support@sick.jp

Nederlands

Phone +31 (0)30 229 25 44
E-Mail info@sick.nl

Norge

Phone +47 67 81 50 00
E-Mail austefjord@sick.no

Österreich

Phone +43 (0)22 36 62 28 8-0
E-Mail office@sick.at

Polska

Phone +48 22 837 40 50
E-Mail info@sick.pl

Republic of Korea

Phone +82-2 786 6321/4
E-Mail kang@sickkorea.net

Republika Slovenija

Phone +386 (0)1-47 69 990
E-Mail office@sick.si

România

Phone +40 356 171 120
E-Mail office@sick.ro

Russia

Phone +7 495 775 05 34
E-Mail info@sick-automation.ru

Schweiz

Phone +41 41 619 29 39
E-Mail contact@sick.ch

Singapore

Phone +65 6744 3732
E-Mail admin@sicksgp.com.sg

Suomi

Phone +358-9-25 15 800
E-Mail sick@sick.fi

Sverige

Phone +46 10 110 10 00
E-Mail info@sick.se

Taiwan

Phone +886 2 2375-6288
E-Mail sickgrc@ms6.hinet.net

Türkiye

Phone +90 216 587 74 00
E-Mail info@sick.com.tr

USA/Canada/México

Phone +1(952) 941-6780
1 800-325-7425 – tollfree
E-Mail info@sickusa.com

More representatives and agencies
in all major industrial nations at
www.sick.com