

LFT level sensor – the all-round talent with TDR technology

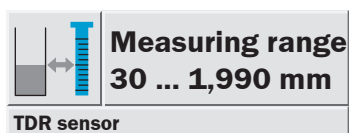

Latest technology: TDR sensor with coaxial probe for continual level measurements with analog and switching output, e.g., as alternative for capacitive sensors.

Measurement principle

The LFT uses the TDR technology (TDR = Time Domain Reflectometry) – a process for determining run times of electromagnetic waves. A low-energy, electromagnetic impulse is generated in the electronics of the sensor, coupled into the coaxial probe and run in the inside of this probe. When this impulse reaches the fluid on the surface to be measured, part of

the impulse is reflected there and runs along the probe back to the electronics, which then calculates the level from the time difference between the impulse sent out and the received on. The sensor can output this as continual measurement value (analog output) as well as derive a freely positionable switching point [S] from it (switching output).

Area of use

Innovative TDR technology enables inexpensive, reliable level measurements largely independent of applications. The LFT is suitable both for continual level measurements and for limit-level detection in almost all fluids; changes in the properties of fluids to be measured do not influence it. It is the solution for precise and reliable measurements, especially in small tanks and containers – independent of installation conditions. Typical applications are, for example, in:

- Coolant lubricants
- Oil
- Other fuel types

SICK

Dimensional drawing

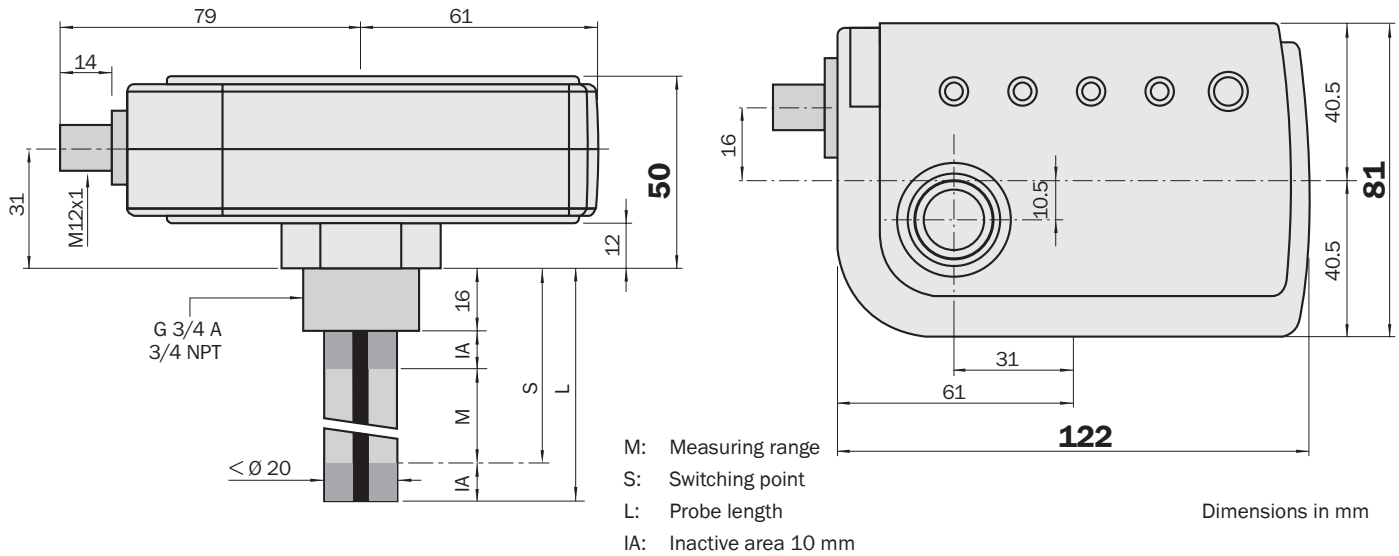

Installation

The sensor is installed vertically from above into the container or tub using its connection thread screw. For example, it can be screwed in directly into a weld-in socket or a mounting bracket. Minimum bracket diameter and maximal bracket height do not apply here.

Install the sensor, so that it does not touch other tank installations (e.g., feed pipes or other measurement equipment), the container wall or the container bottom (the use of the supplied gasket with a height of 2 mm might be sufficient here). Minimum distances do not apply here.

Select the installation spot, so that the sensor is not exposed directly to filling. The sensor should not be installed in a calm area of the container, in which sediment could settle over time (e.g., sanding dust). Continual rinsing of the sensor via moving fluid is recommended.

Operation

The sensor can be configured completely via the button. Visual feedback via the LEDs help here. You can make the following settings directly on the sensor:

- Set and delete via Teach-in the switching point [S] for the switching output
- Set the hysteresis for the switching outputs
- Set the actual measurement range for the current output
- Reset the sensor to the ex works state

Please read the operating instructions for a detailed explanation of operation

Approvals

No special, application-related approvals are currently required for the sensor.

Connection type

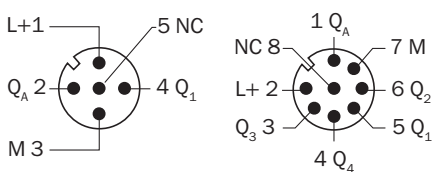

Pin	Male connector 5-pin	Wire colour cable terminal box	Male connector 8-pin	Wire colour cable terminal box
1	+U _V (18 ... 30 V DC)	brown (brn)	Analog output Q _A	white (wht)
2	Analog output Q _A	white (wht)	+U _V (18 ... 30 V DC)	brown (brn)
3	0 V	blue (blu)	Switching output Q ₃	green (grn)
4	Switching output Q ₁	black (blk)	Switching output Q ₄	yellow (yel)
5		don't connect	Switching output Q ₁	gray (gra)
6			Switching output Q ₂	pink (pnk)
7			0 V	blue (blu)
8				don't connect

Technical data**Electric data**

Output functions Analog output 4 ... 20 mA Namur
and/or switching output PNP ¹⁾

Analogue output

Burden by 4 ... 20 mA < 500 Ω
Lower signal level 3.8 ... 4.0 mA
Upper signal level 20 ... 20.5 mA
Operating time 200 mS

Switching output²⁾

Signal voltage HIGH $V_S - 2 V$
Signal voltage LOW $0 V \leq 1 V$
Output current I_A < 200 mA

Output load

Capacitive load 100 nF
Inductive load 1 H
Operating time 200 ms

Supply voltage V_S ³⁾ 18 ... 30 VDC
Residual ripple $\leq 5 V_{pp}$
Current consumption ⁴⁾ < 90 mA at 24 VDC
Protection class III
Initialization time < 4 s
Connection types Plug M12, 5-pin
Plug M12, 8-pin

Measurement performance⁵⁾

Accuracy $\pm 3 \text{ mm}$
Reproducibility < 2 mm
Resolution < 1 mm
Hysteresis switching output 3 mm or free adjustable
Temperature drift 0.05 mm/K
Measuring range [M] 30 ... 1,990 mm (at probe length 2,000 mm)
Inactive area ⁶⁾ Each 10 mm

Application conditions

Dielectricity constant [ϵ_r] ⁷⁾ ≥ 1.8 ⁸⁾
Conductivity ⁷⁾ No restrictions
Temperature ⁹⁾ 0 ... +80 °C
Ambient temperature ⁹⁾ Operation -10 ... +60 °C
Storage -40 ... +80 °C
Container pressure 1 bar rel. (during filling and emptying processes)
Separating layer (e.g., oil on water) ¹⁰⁾ > 70 mm

Mechanical data

Enclosure rating IP 67
Connection thread screw G 3/4 A; 3/4" NPT
Probe length [L] 200 ... 2,000 mm
Material Housing PBT
Probe 316 L / 1.4404
Seal/probe end 1.4404 / 1.4310 / PTFE

- ¹⁾ Freely positionable in the complete measurement range
²⁾ Switching output short-circuit protected
³⁾ Connections reverse-polarity protected
⁴⁾ Without load
⁵⁾ Reference condition: Dielectricity constant [ϵ_r] = 80 (water); with changed ϵ_r , measurement performance and the inactive range change.

- ⁶⁾ At top and bottom plus tolerances of measurement accuracy
⁷⁾ Fluid to be measured
⁸⁾ Suitable for all oils, e.g., cutting, grinding and hydraulic oils, coolant lubricants, erosion dielectrics, cleaning and degreasing agents, all fluid lubricants, water and water-based fluids

- ⁹⁾ We recommend using a distance sleeve with simultaneous max. medium temperature and max. ambient temperature (see accessories).

- ¹⁰⁾ The sensor does not detect an oil layer of < 70 mm on water, i.e., the sensor detects the water level. Starting from an oil layer of > 70 mm, the complete level is detected, i.e., the level incl. the oil layer.

Type code	LFT												Optional				
Probe length in mm (value x 10)					0	-	0										
From 200 mm	0	2	0														
To 2000 mm	2	0	0														
Connection thread screw tank																	
G 3/4 A										1							
3/4" NPT										2							
Connection housing																	
M12x1, 5-pin (max. 1 switching output possible)												A					
M12x1, 8-pin (min. 2 switching outputs)												B					
Analog output																	
Measurement value output (only with 4 switching outputs)												0					
Current output 4 ... 20 mA												1					
Switching output																	
Normally closed (NC)													A				
Normally open (NO)													B				
2 x NC and 2 x NO (only for 4 switching points)													C				
Switching outputs/switching points (number)																	
1 Switching output, hysteresis locked, 3 mm																1	
2 Switching outputs, hysteresis locked, 3 mm																2	
4 Switching outputs, hysteresis locked, 3 mm																4	
1 Switching output, hysteresis adjustable																5	
2 Switching outputs, hysteresis adjustable																6	
Optional: Device type																	
Customized factory settings																W	0 0

Customized factory settings ¹⁾

Switching point hysteresis locked, (3 mm)

Position switching point [S] (1-4) mm

Switching point, hysteresis adjustable

Position of upper switching thresholds mm
[S] (1-4)

Position of lower switching thresholds mm
[S] (1-4)

Analog current output

Upper value [20 mA] mm

Lower value [4 mA] mm

¹⁾ The sealing surface of the screw-in thread of the probe is the reference point for customer-specific setting (see dimensional drawing)

Order information

You can obtain the sensor pre-configured for your requirements by selecting the appropriate options in the order code.

Default setting:

- Measurement range [M] has the maximum extension between the inactive areas at the top and bottom (each 10 mm).
- The lower signal level of the analog output (4 mA) is at the lower probe end, the upper signal level (20 mA) at the upper probe end.

Order information *

Output: 1 current output (4 ... 20 mA) and 1 switching output/hysteresis: 3 mm

Type	Order no.	Probe length	Connection thread screw tank	Connection plug housing	Current output	Switching output Normally closed
LFT0200-01A1A10	1043593	200 mm	G 3/4 A	M12x1, 5-pin	4 ... 20 mA	1
LFT0300-01A1A10	1043594	300 mm	G 3/4 A	M12x1, 5-pin	4 ... 20 mA	1
LFT0400-01A1A10	1043595	400 mm	G 3/4 A	M12x1, 5-pin	4 ... 20 mA	1
LFT0500-01A1A10	1043596	500 mm	G 3/4 A	M12x1, 5-pin	4 ... 20 mA	1
LFT0600-01A1A10	1043597	600 mm	G 3/4 A	M12x1, 5-pin	4 ... 20 mA	1
LFT0700-01A1A10	1043598	700 mm	G 3/4 A	M12x1, 5-pin	4 ... 20 mA	1
LFT0800-01A1A10	1043599	800 mm	G 3/4 A	M12x1, 5-pin	4 ... 20 mA	1
LFT0900-01A1A10	1043600	900 mm	G 3/4 A	M12x1, 5-pin	4 ... 20 mA	1
LFT1000-01A1A10	1043601	1000 mm	G 3/4 A	M12x1, 5-pin	4 ... 20 mA	1
LFT1100-01A1A10	1043602	1100 mm	G 3/4 A	M12x1, 5-pin	4 ... 20 mA	1
LFT1200-01A1A10	1043603	1200 mm	G 3/4 A	M12x1, 5-pin	4 ... 20 mA	1
LFT1300-01A1A10	1043604	1300 mm	G 3/4 A	M12x1, 5-pin	4 ... 20 mA	1
LFT1400-01A1A10	1043605	1400 mm	G 3/4 A	M12x1, 5-pin	4 ... 20 mA	1
LFT1500-01A1A10	1043606	1500 mm	G 3/4 A	M12x1, 5-pin	4 ... 20 mA	1
LFT1600-01A1A10	1043607	1600 mm	G 3/4 A	M12x1, 5-pin	4 ... 20 mA	1
LFT1700-01A1A10	1043608	1700 mm	G 3/4 A	M12x1, 5-pin	4 ... 20 mA	1
LFT1800-01A1A10	1043609	1800 mm	G 3/4 A	M12x1, 5-pin	4 ... 20 mA	1
LFT1900-01A1A10	1043610	1900 mm	G 3/4 A	M12x1, 5-pin	4 ... 20 mA	1
LFT2000-01A1A10	1043611	2000 mm	G 3/4 A	M12x1, 5-pin	4 ... 20 mA	1

Output: 4 switching output/hysteresis: 3 mm

Type	Order no.	Probe length	Connection thread screw tank	Connection plug housing	Current output	Switching output Normally closed
LFT0200-01B0A40	1043612	200 mm	G 3/4 A	M12x1, 8-pin	—	4
LFT0300-01B0A40	1043613	300 mm	G 3/4 A	M12x1, 8-pin	—	4
LFT0400-01B0A40	1043614	400 mm	G 3/4 A	M12x1, 8-pin	—	4
LFT0500-01B0A40	1043615	500 mm	G 3/4 A	M12x1, 8-pin	—	4
LFT0600-01B0A40	1043616	600 mm	G 3/4 A	M12x1, 8-pin	—	4
LFT0700-01B0A40	1043617	700 mm	G 3/4 A	M12x1, 8-pin	—	4
LFT0800-01B0A40	1043618	800 mm	G 3/4 A	M12x1, 8-pin	—	4
LFT0900-01B0A40	1043619	900 mm	G 3/4 A	M12x1, 8-pin	—	4
LFT1000-01B0A40	1043620	1000 mm	G 3/4 A	M12x1, 8-pin	—	4
LFT1100-01B0A40	1043621	1100 mm	G 3/4 A	M12x1, 8-pin	—	4
LFT1200-01B0A40	1043622	1200 mm	G 3/4 A	M12x1, 8-pin	—	4
LFT1300-01B0A40	1043623	1300 mm	G 3/4 A	M12x1, 8-pin	—	4
LFT1400-01B0A40	1043624	1400 mm	G 3/4 A	M12x1, 8-pin	—	4
LFT1500-01B0A40	1043625	1500 mm	G 3/4 A	M12x1, 8-pin	—	4
LFT1600-01B0A40	1043626	1600 mm	G 3/4 A	M12x1, 8-pin	—	4
LFT1700-01B0A40	1043627	1700 mm	G 3/4 A	M12x1, 8-pin	—	4
LFT1800-01B0A40	1043628	1800 mm	G 3/4 A	M12x1, 8-pin	—	4
LFT1900-01B0A40	1043629	1900 mm	G 3/4 A	M12x1, 8-pin	—	4
LFT2000-01B0A40	1043630	2000 mm	G 3/4 A	M12x1, 8-pin	—	4

Output: 1 current output (4 ... 20 mA) and 2 switching outputs/hysteresis: 3 mm

Type	Order no.	Probe length	Connection thread screw tank	Connection plug housing	Current output	Switching output Normally closed
LFT0200-01B1A20	1043631	200 mm	G 3/4 A	M12x1, 8-pin	4 ... 20 mA	2
LFT0300-01B1A20	1043632	300 mm	G 3/4 A	M12x1, 8-pin	4 ... 20 mA	2
LFT0400-01B1A20	1043633	400 mm	G 3/4 A	M12x1, 8-pin	4 ... 20 mA	2
LFT0500-01B1A20	1043634	500 mm	G 3/4 A	M12x1, 8-pin	4 ... 20 mA	2
LFT0600-01B1A20	1043635	600 mm	G 3/4 A	M12x1, 8-pin	4 ... 20 mA	2
LFT0700-01B1A20	1043636	700 mm	G 3/4 A	M12x1, 8-pin	4 ... 20 mA	2
LFT0800-01B1A20	1043637	800 mm	G 3/4 A	M12x1, 8-pin	4 ... 20 mA	2
LFT0900-01B1A20	1043638	900 mm	G 3/4 A	M12x1, 8-pin	4 ... 20 mA	2
LFT1000-01B1A20	1043639	1000 mm	G 3/4 A	M12x1, 8-pin	4 ... 20 mA	2

* Other models on request.

Dimensional drawings and order information*

Output: 1 current output (4 ... 20 mA) and 2 switching outputs/hysteresis: 3 mm

Type	Order no.	Probe length	Connection thread screw tank	Connection plug housing	Current output	Switching output Normally closed
LFT1100-01B1A20	1043640	1100 mm	G 3/4 A	M12x1, 8-pin	4 ... 20 mA	2
LFT1200-01B1A20	1043641	1200 mm	G 3/4 A	M12x1, 8-pin	4 ... 20 mA	2
LFT1300-01B1A20	1043642	1300 mm	G 3/4 A	M12x1, 8-pin	4 ... 20 mA	2
LFT1400-01B1A20	1043643	1400 mm	G 3/4 A	M12x1, 8-pin	4 ... 20 mA	2
LFT1500-01B1A20	1043644	1500 mm	G 3/4 A	M12x1, 8-pin	4 ... 20 mA	2
LFT1600-01B1A20	1043645	1600 mm	G 3/4 A	M12x1, 8-pin	4 ... 20 mA	2
LFT1700-01B1A20	1043646	1700 mm	G 3/4 A	M12x1, 8-pin	4 ... 20 mA	2
LFT1800-01B1A20	1043647	1800 mm	G 3/4 A	M12x1, 8-pin	4 ... 20 mA	2
LFT1900-01B1A20	1043648	1900 mm	G 3/4 A	M12x1, 8-pin	4 ... 20 mA	2
LFT2000-01B1A20	1043649	2000 mm	G 3/4 A	M12x1, 8-pin	4 ... 20 mA	2

Output 4 Switching outputs- 2 normally closed and 2 normally open/hysteresis: 3 mm

Type	Order no.	Probe length	Connection thread screw tank	Connection plug housing	Current output	Switching output NC/NO
LFT0200-01B0C40	1048239	200 mm	G 3/4 A	M12x1, 8-pin	—	2 / 2
LFT0300-01B0C40	1048240	300 mm	G 3/4 A	M12x1, 8-pin	—	2 / 2
LFT0400-01B0C40	1048241	400 mm	G 3/4 A	M12x1, 8-pin	—	2 / 2
LFT0500-01B0C40	1048201	500 mm	G 3/4 A	M12x1, 8-pin	—	2 / 2
LFT0600-01B0C40	1048242	600 mm	G 3/4 A	M12x1, 8-pin	—	2 / 2
LFT0700-01B0C40	1048243	700 mm	G 3/4 A	M12x1, 8-pin	—	2 / 2
LFT0800-01B0C40	1048244	800 mm	G 3/4 A	M12x1, 8-pin	—	2 / 2
LFT0900-01B0C40	1048202	900 mm	G 3/4 A	M12x1, 8-pin	—	2 / 2
LFT1000-01B0C40	1048245	1000 mm	G 3/4 A	M12x1, 8-pin	—	2 / 2
LFT1100-01B0C40	1048246	1100 mm	G 3/4 A	M12x1, 8-pin	—	2 / 2
LFT1200-01B0C40	1048247	1200 mm	G 3/4 A	M12x1, 8-pin	—	2 / 2
LFT1300-01B0C40	1048248	1300 mm	G 3/4 A	M12x1, 8-pin	—	2 / 2
LFT1400-01B0C40	1048249	1400 mm	G 3/4 A	M12x1, 8-pin	—	2 / 2
LFT1500-01B0C40	1048250	1500 mm	G 3/4 A	M12x1, 8-pin	—	2 / 2
LFT1600-01B0C40	1048251	1600 mm	G 3/4 A	M12x1, 8-pin	—	2 / 2
LFT1700-01B0C40	1048252	1700 mm	G 3/4 A	M12x1, 8-pin	—	2 / 2
LFT1800-01B0C40	1048253	1800 mm	G 3/4 A	M12x1, 8-pin	—	2 / 2
LFT1900-01B0C40	1048254	1900 mm	G 3/4 A	M12x1, 8-pin	—	2 / 2
LFT2000-01B0C40	1048255	2000 mm	G 3/4 A	M12x1, 8-pin	—	2 / 2

* Other models on request.

Cables and connectors

SENSICK srew system M12, 5-pin, enclosure rating IP 67

Female connector M12, 5-pin, straight

5 x 1 mm ² , sheath PVC			
Type	Order no.	Contacts	Cable length
DOL-1205-G02M	6008899	5	2 m
DOL-1205-G05M	6009868	5	5 m
DOL-1205-G10M	6010544	5	10 m

Female connector M12, 5-pin, angled

5 x 1 mm ² , sheath PVC			
Type	Order no.	Contacts	Cable length
DOL-1205-W02M	6008900	5	2 m
DOL-1205-W05M	6009869	5	5 m
DOL-1205-W10M	6010542	5	10 m

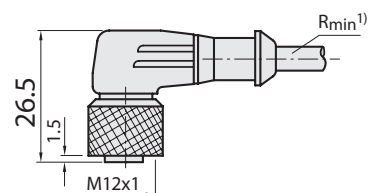
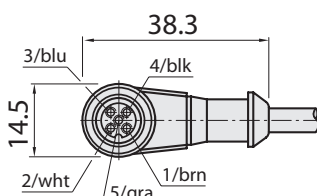
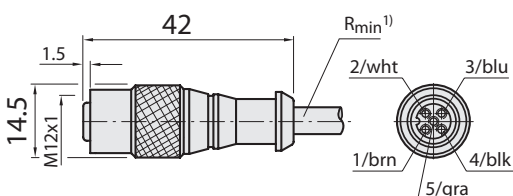

¹⁾ Minimum bend radius in dynamic use
R_{min} = 20 x cable diameter

Dimensional drawings and order information

Cables and connectors

SENSICK screw-in system M12, 8-pin, enclosure rating IP 67

Female connector M12, 8-pin, straight			
8 x 1 mm ² , sheath PVC			
Type	Order no.	Contacts	Cable length
DOL-1208-G02M	6020633	8	2 m
DOL-1208-G05M	6020993	8	5 m
DOL-1208-G10M	6022152	8	10 m

Female connector M12, 8-pin, angled			
8 x 1 mm ² , sheath PVC			
Type	Order no.	Contacts	Cable length
DOL-1208-W02MA	6020992	8	2 m
DOL-1208-W05MA	6021033	8	5 m

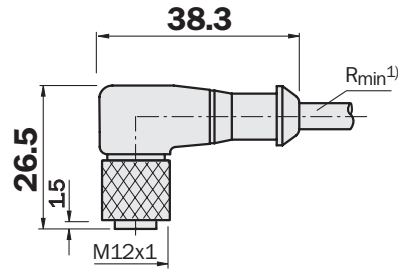
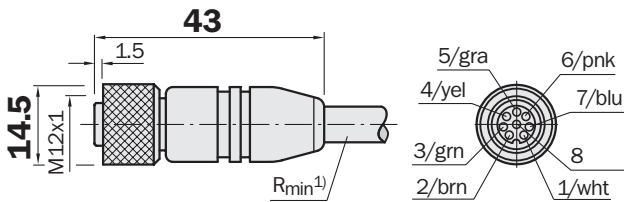

Female connector M12, 5- or 8-pin, straight			
5 x 1 mm ² or 8 x 1.5 mm ² , sheath PUR halogenfree			
Type	Order no.	Contacts	Cable length
DOL-1205-G02MC	6025906	5	2 m
DOL-1205-G05MC	6025907	5	5 m
DOL-1205-G10MC	6025908	5	10 m
DOL-1208-G02MC	6035620	8	2 m
DOL-1208-G05MC	6035621	8	5 m
DOL-1208-G10MC	6035622	8	10 m

Female connector M12, 5- or 8-pin, angled			
5 x 1 mm ² or 8 x 1.5 mm ² , sheath PUR halogenfree			
Type	Order no.	Contacts	Cable length
DOL-1205-W02MC	6025909	5	2 m
DOL-1205-W05MC	6025910	5	5 m
DOL-1205-W10MC	6025911	5	10 m
DOL-1208-W02MC	6035623	8	2 m
DOL-1208-W05MC	6035624	8	5 m
DOL-1208W10MC	6035625	8	10 m

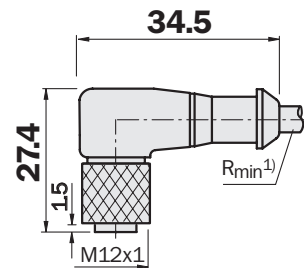
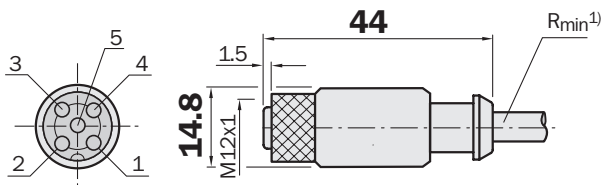

1) Minimum bend radius in dynamic use
R_{min} = 20 x cable diameter

Power supply, 100 ... 240 V AC/24 V DC, 2.1 A, IP 20

Type	Order no.
Power supply	7028789

Welded flange	
Type	Order no.
G 3/4, 1.4404	4054604

Counter-nut	
Type	Order no.
3/4" NPT, PA	5321680

Distance sleeve	
Type	Order no.
G 3/4, stainless steel	2047331
3/4" NPT, stainless steel	2046464

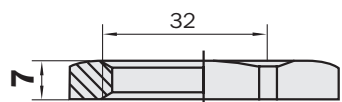
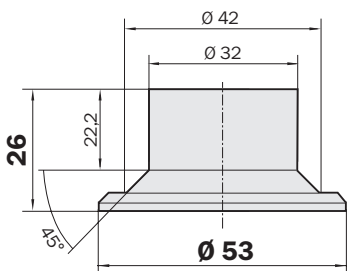

Type	Order no.
G 3/4, PA	5321681

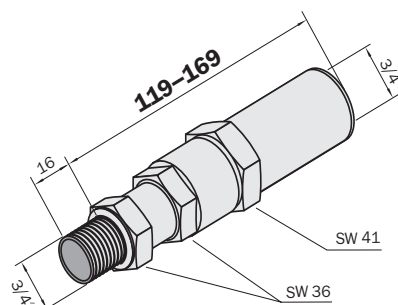

Australia

Phone +61 3 9497 4100
1800 33 48 02 – tollfree
E-Mail sales@sick.com.au

Belgium/Luxembourg

Phone +32 (0)2 466 55 66
E-Mail info@sick.be

Brasil

Phone +55 11 3215-4900
E-Mail sac@sick.com.br

Ceská Republika

Phone +420 2 57 91 18 50
E-Mail sick@sick.cz

China

Phone +852-2763 6966
E-Mail ghk@sick.com.hk

Danmark

Phone +45 45 82 64 00
E-Mail sick@sick.dk

Deutschland

Phone +49 211 5301-250
E-Mail info@sick.de

España

Phone +34 93 480 31 00
E-Mail info@sick.es

France

Phone +33 1 64 62 35 00
E-Mail info@sick.fr

Great Britain

Phone +44 (0)1727 831121
E-Mail info@sick.co.uk

India

Phone +91-22-4033 8333
E-Mail info@sick-india.com

Israel

Phone +972-4-999-0590
E-Mail info@sick-sensors.com

Italia

Phone +39 02 27 43 41
E-Mail info@sick.it

Japan

Phone +81 (0)3 3358 1341
E-Mail support@sick.jp

Nederlands

Phone +31 (0)30 229 25 44
E-Mail info@sick.nl

Norge

Phone +47 67 81 50 00
E-Mail austefjord@sick.no

Österreich

Phone +43 (0)22 36 62 28 8-0
E-Mail office@sick.at

Polska

Phone +48 22 837 40 50
E-Mail info@sick.pl

Republic of Korea

Phone +82-2 786 6321/4
E-Mail kang@sickkorea.net

Republika Slovenija

Phone +386 (0)1-47 69 990
E-Mail office@sick.si

România

Phone +40 356 171 120
E-Mail office@sick.ro

Russia

Phone +7 495 775 05 34
E-Mail info@sick-automation.ru

Schweiz

Phone +41 41 619 29 39
E-Mail contact@sick.ch

Singapore

Phone +65 6744 3732
E-Mail admin@sicksgp.com.sg

Suomi

Phone +358-9-25 15 800
E-Mail sick@sick.fi

Sverige

Phone +46 10 110 10 00
E-Mail info@sick.se

Taiwan

Phone +886 2 2375-6288
E-Mail sickgrc@ms6.hinet.net

Türkiye

Phone +90 216 587 74 00
E-Mail info@sick.com.tr

USA/Canada/México

Phone +1(952) 941-6780
1 800-325-7425 – tollfree
E-Mail info@sickusa.com

More representatives and agencies
in all major industrial nations at
www.sick.com